

WESMAN

FOUNDRY EQUIPMENT DIVISION

CONTINUOUS CORE OVEN

FOUNDRY EQUIPMENT

WESMAN OIL FIRED VERTICAL CONTINUOUS CORE DRYING OVENS are used to dry cores of various sizes. The casing is of insulated sheet steel panels with leak-proof joints, designed for assembly at site.

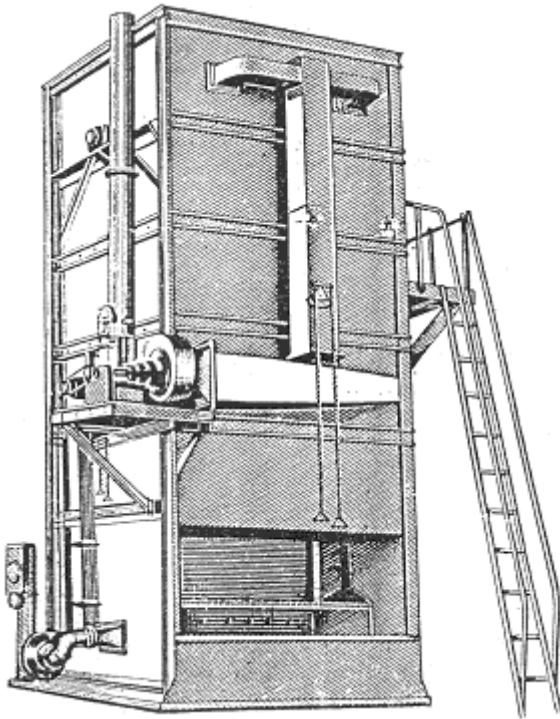

The combustion chamber has a Wesman oil burner which runs on HSD, LDO, LSHS or furnace oil. For efficient combustion a Wesman pumping and heating unit is also provided. Gas firing is optionally available on request. Combustion air is supplied to the burner from a Wesman centrifugal blower. A hot air circulation fan is also provided with necessary ducting. Part of the hot gases are exhausted through the chimney located in the duct.

OPTIONAL: ■ OIL SERVICE TANK ■ OUTFLOW HEATER ■ MOTOR STARTER ■ SEMI-ROTARY PUMP FOR OIL TANK ■ FUME EXTRACTION UNIT

SEE REVERSE FOR INSTALLATION DIMENSIONS

Core loading and unloading stations are at opposite sides of the oven. The cores are loaded on carriages hung from two conveying chains which are suspended from specially designed sprockets located on top of the casing frame. A fabricated frame keeps the conveying chains in tension. The top sprockets are driven by a suitably sized motor through a worm reduction gearbox with provisions for speed variation. A shear pin arrangement is also provided to avoid damage to the carriages and cores in case of any jamming during running of the oven. The combustion chamber is lined at site with refractories supplied by us.

STAR FEATURES

- ▶ Rugged construction
- ▶ Saves floor space
- ▶ Easy to operate and maintain
- ▶ Fitted with Wesman's highly acclaimed combustion equipment
- ▶ Countrywide after-sales service
- ▶ Wesman quality built into every machine

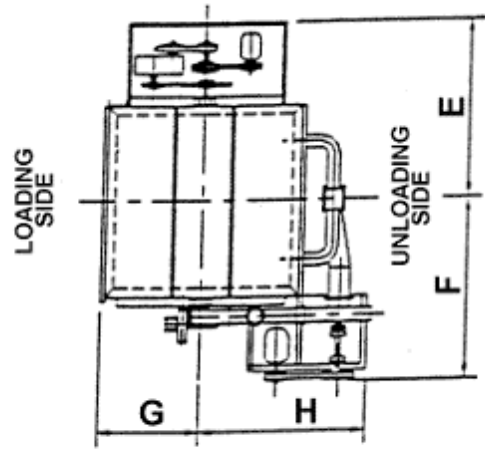
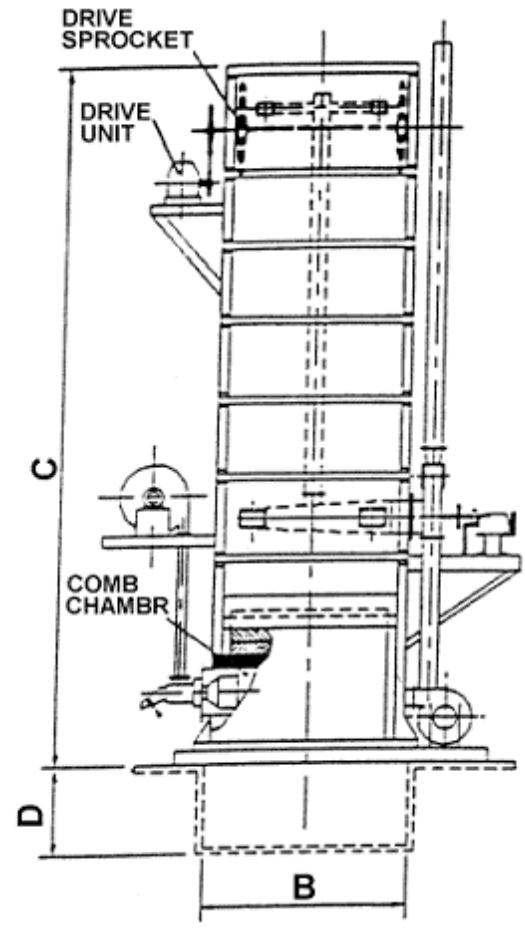
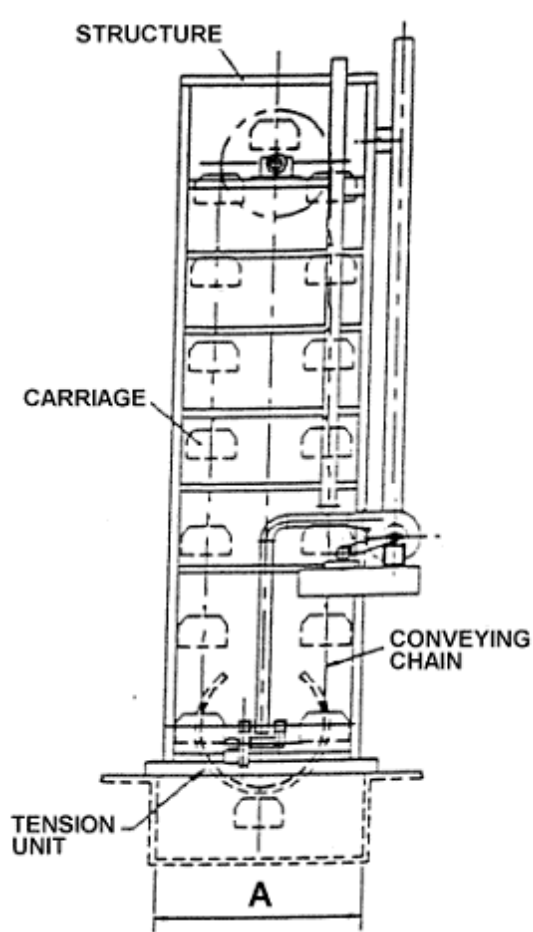

TECHNICAL DATA FOR ALL MODELS

OPERATING TEMPERATURE: 170 DEG C TO 300 DEG C
 STANDARD DRYING CYCLE: 90 MIN
 MAX CORE HEIGHT ON BOTTOM TRAY: 185 MM
 MAX CORE HEIGHT ON TOP TRAY: 280 MM
 MAX CORE HEIGHT WITHOUT TOP TRAY: 535 MM
 MAX LOAD PER CARRIAGE: 140 KG

MODEL	DIMENSIONS IN MM								MAX CORE PLATE SIZE	TOTAL CARRIAGES	TRAYS PER CARRIAGE
	A	B	C	D	E	F	G	H			
2S	2400	2220	4750	1000	2160	2100	1265	1900	1575 x 600	14	2
V1	2400	2450	4750	1000	2275	2225	1265	1900	1825 x 600	14	2
V2	2400	2450	6365	1000	2475	2225	1265	1800	1825 x 600	18	2
V3	2400	2450	7960	1000	2275	2225	1265	1800	1825 x 600	22	2

ALL DIMENSIONS ARE APPROXIMATE AND NON-BINDING



THE WESMAN ENGINEERING CO PVT LTD

WESMAN CENTER, 8 MAYFAIR ROAD, KOLKATA 700019, INDIA
 TEL: +91 (33) 22405320, 22816406
 FAX: +91 (33) 22478050, 22816402
 EMAIL: foundry@wesman.com INTERNET: www.wesman.com

KOLKATA ■ NEW DELHI ■ MUMBAI ■ CHENNAI ■ PUNE ■ BANGALORE ■ AHMEDABAD ■ HYDERABAD